

Instruction Manual

Vibrating Table

Model: 2615061, 300 W, 220V, 60Hz, 2ph

Model: 2615062, 300 W, 220V, 50Hz, 1ph



Please read this instruction before moving and installing this machine and attempting to run it.

- **Check out any accessories you have received with your packing list which are electrical control box, two screwed (M16) rods, one steel bar.**
- **This machine generates sound and vibration.**
- **The machine should be leveled and fixed on the concrete surface.**
- **The power supply should be connected to earth wire(Ground) for electrical shockproofing.**

Table of Contents

Contents

- 1- Introduction**
- 2- Specifications and Accessories of Hardware**
- 3- Schematic Drawing**
- 4- How to install the Vibrating Table properly.**
- 5- Prepare the Vibrating Table**
- 6- How to fix the samples on the table.**
- 7- Starting machine for the vibrating process.**
- 8- How to adjust the amplitude of the Vibrating Table.**
- 9- Regularly cleaning the machine after process completion**
- 10- Troubleshooting**
- 11- Service life**

1. Introduction

Concrete Vibrating Table is used for consolidating fresh concrete when forming cylinder and beam molds. The unit has a 700x700mm (27.5x27.5 in) large platform with a load capacity of up to 300kg (660 lb). The electrical vibrating table comes with a separate control unit with an on/off switch, timer, and emergency bottom of 3,600 vibrations per minute. The power cable to the vibrating table is user-supplied. If all the things mentioned in the brochure or manual are followed, this Vibrating Table can be used for other industrial or laboratory purposes.

2. Specification and Accessories of Hardware

- 1- Table size: 700x700mm (27.5x27.5 in)**
- 2- Comes with two screwed rods with nuts(M16) and a steel cross bar holder for fixing molds or other objects on the table.**
- 3- Control Box with an on/off switch, timer, and emergency bottom. The power cable to the vibrating table is user-supplied.**
- 4- Maximum Carrying Load: 200 Kg**
- 5-High Quality, Heavy duty steel welded structure.**
- 6- Adjustable amplitude by adjusting counter balances weights of motor (Read how to adjust the table amplitude)**
- 7- Model: 2615061, 300W, 220V, 60Hz, 2ph, 3600 rpm**
- 8-Model: 2615062, 300W, 220V, 50Hz, 1ph, 3000 rpm**
- 9- Dimension: 700x700x380mm**
- 10- Estimated Weight: 90kg**

For more details and updating visit: www.cantrol.ca

3. Schematic Drawing

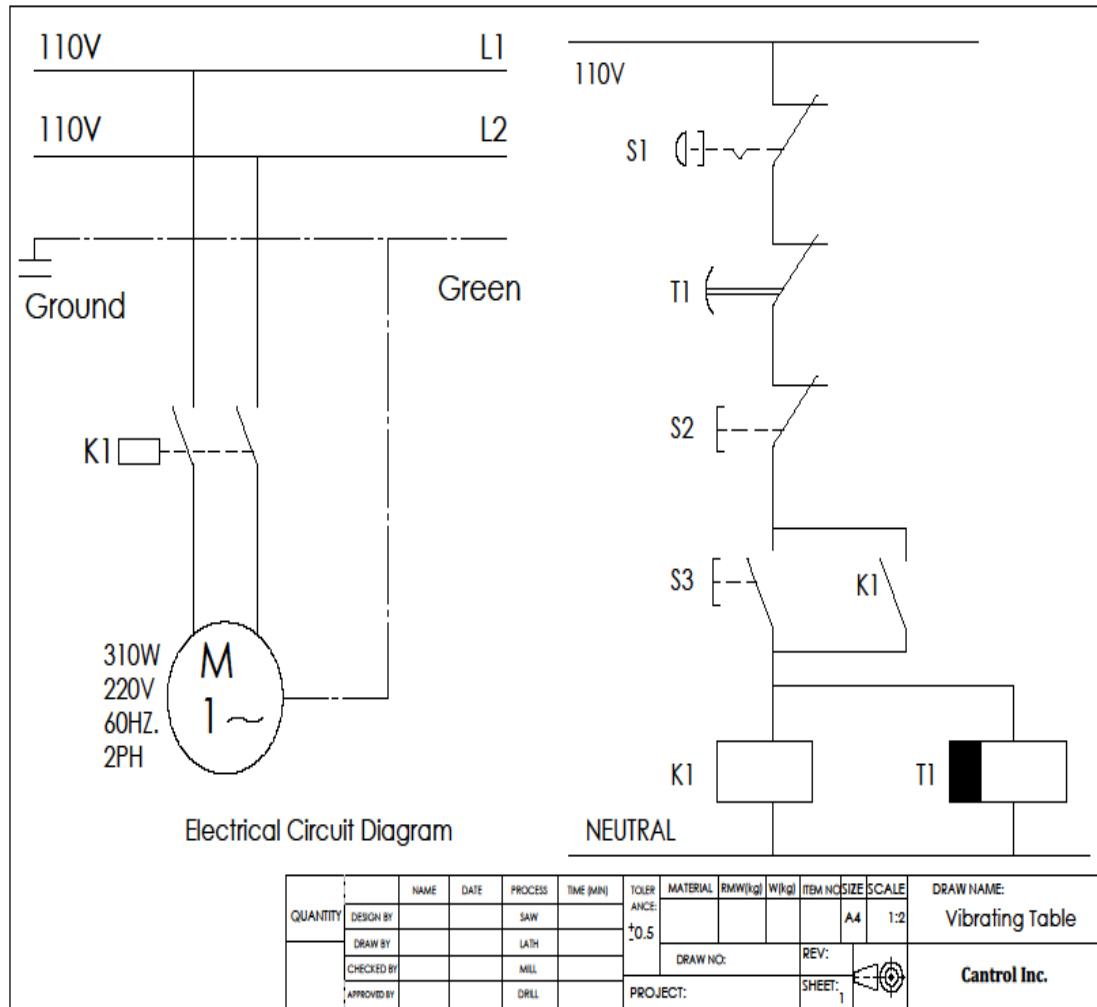

Figure 1(electrical circuit diagram) Model: 2615061

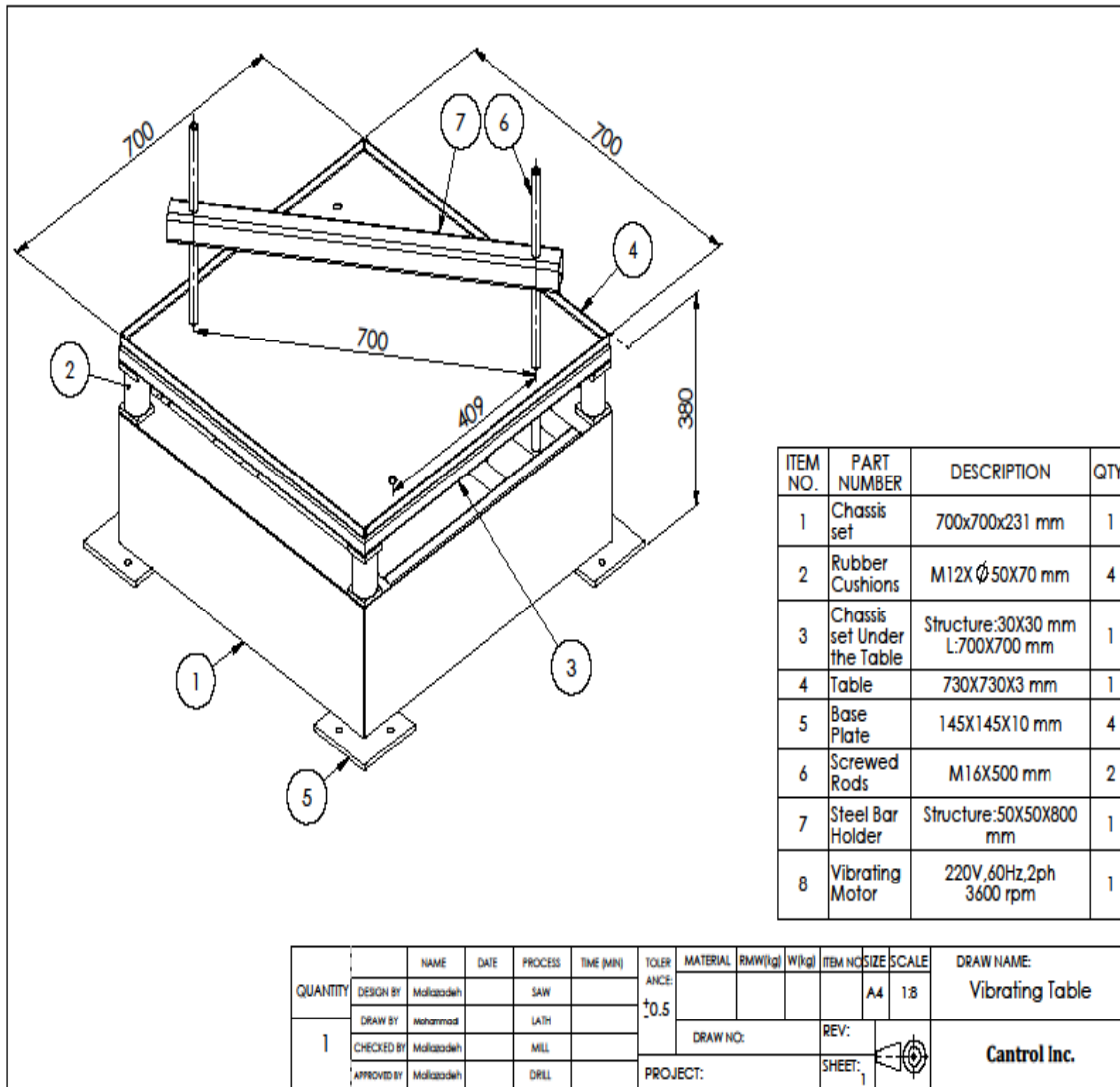

Figure 2

4- How to install the Vibrating Table properly

- Install the machine in the proper place, level, and fix the base plates to the ground securely.
- Plug the machine's wire to the nearest outlet. Be sure that the outlet support 110V (two hotlines), 60Hz., 2ph. Model: 2615061

5- Prepare the Vibrating Table before using

- **There are two screwed rods that should be fastened to the table tightly.**

6- How to fix the samples on the table.

For better productivity of the table fix the items that need to be shaken with a steel cross bar using two M16 nuts and washers

7- Starting machine for the vibrating process.

- **Now, the vibrating table is ready, set the time by turning the nub to a desired time.**
- **The machine starts vibrating the thing to be fixed, till the time of working over.**

8- How to adjust the amplitude of the Vibrating Table.

- **Eccentric weights: Allow continuous adjustments of the centrifugal force. This adjustment is realized by a graduated scale, which expresses the centrifugal force as a percentage of the maximum centrifugal force. By eccentric weights adjustment you will find the best amplitude for your purpose.**

9- Regularly cleaning the machine after vibration completion

- **It is important to clean the machine after daily use, as deposits will build up on the top of the table and cause problems for the next test.**

10- Troubleshooting

● If the normal sound of vibration changes, check all the screws and nuts whether they are loose or broken. Fasten any loosening nuts or screws and change them if they are broken.

Use appropriate steel washers and steel spring washers to ensure that all are fixed tightly.

11- Service life

- 1- Lubrication: All vibrators are lubricated in the factory and do not require further lubrication if used in normal operating conditions.**
- 2- Check the Rubber Cushions for any wear or tear, and ask us a replacement Rubber Cushions if needed.**

For more details and updating visit: www.cantrol.ca

